

Digital Fuel Gauge

P/n 301.530

(With Dual Ohms Range option)

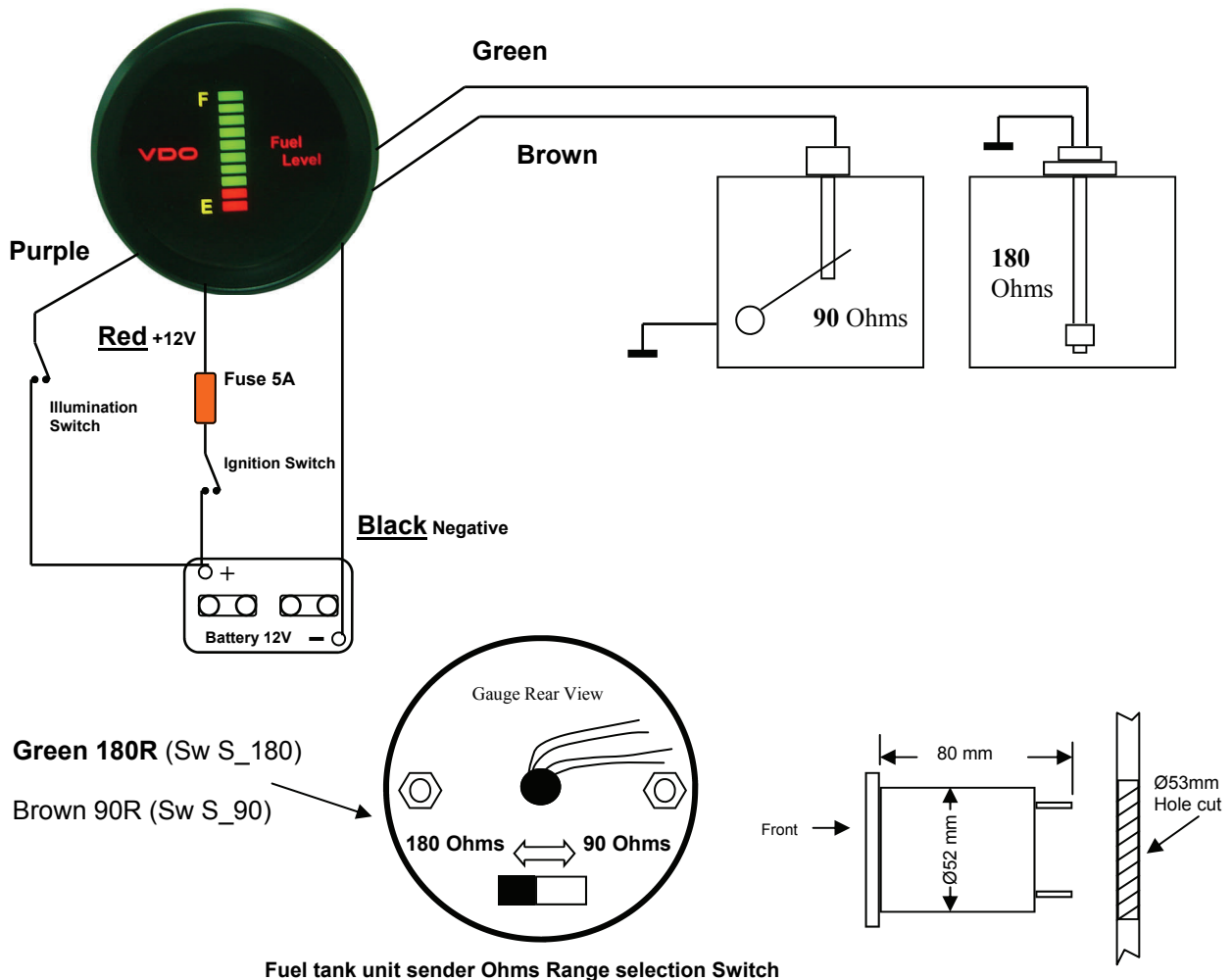

Installation

1. Cut a Ø53mm diameter hole and fit gauge.
2. Connect the **black** wire to a good chassis ground.
Ensure good ground connection between temperature sender unit.
3. Connect the **red** wire to a fuse accessory or the ignition switch circuit.
4. Connect the gauge **signal** wires to the fuel sensors terminal as per above picture.
5. Select fuel tank sender resistor range, 3 - 180 Ohms or 5 -90 Ohms, using Switch at rear of gauge.

Dimmer: the bargraphs will not dim, only the letters will dim.

Digital Dual Fuel Gauge

P/n 301.550
(With Dual Ohms Range option)

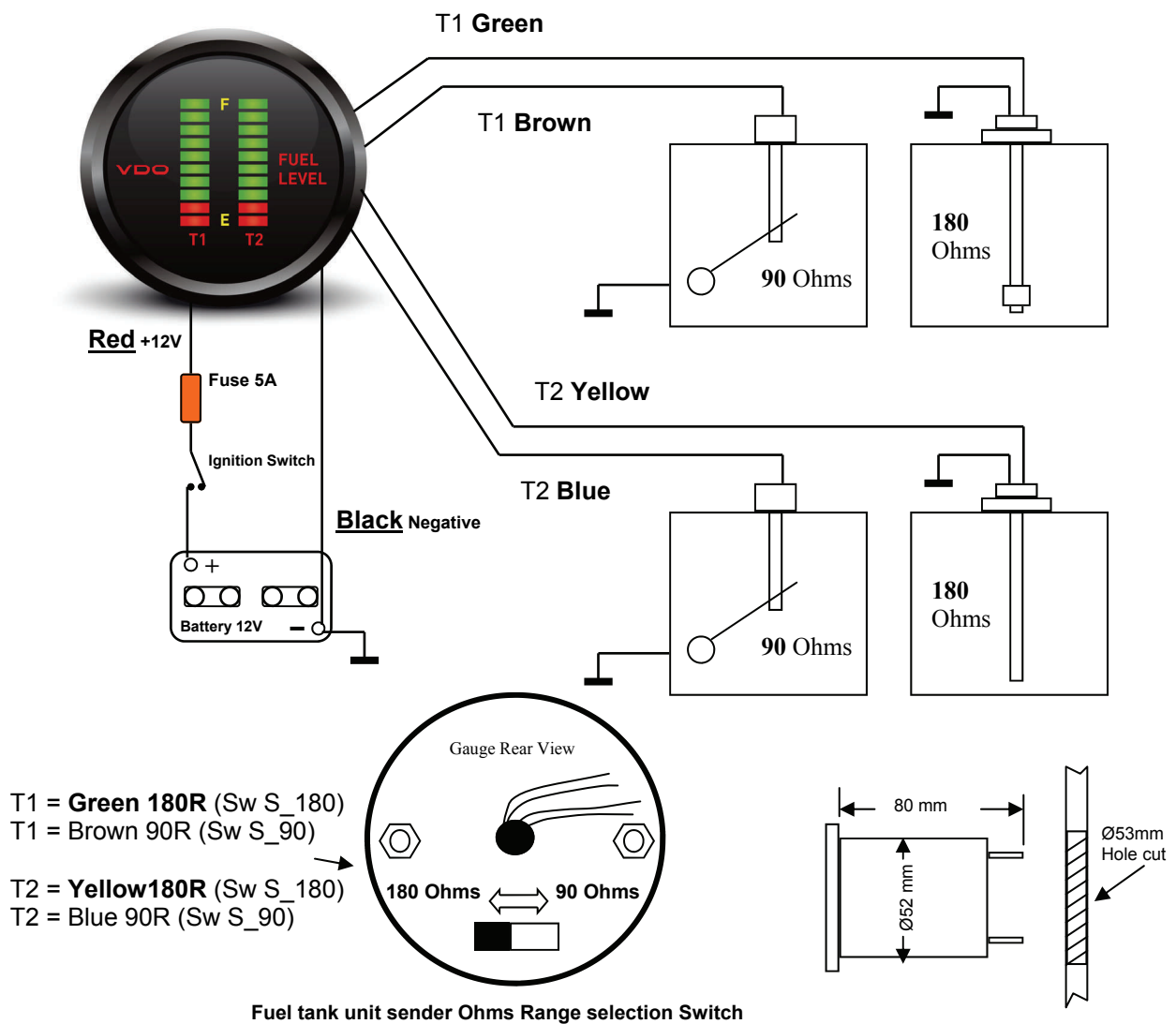

Installation

1. Cut a Ø53mm diameter hole and fit gauge.
2. Connect the **black** wire to a good chassis ground.
Ensure good ground connection between temperature sender unit.
3. Connect the **red** wire to a fuse accessory or the ignition switch circuit.
4. Connect the gauge **signal** wires, T1 and T2 to the fuel sensors terminal as per above picture.

Note: Dimmer is not available on the Dual Tank Gauge

Digital Dual Volt Gauge

P/n 332.540

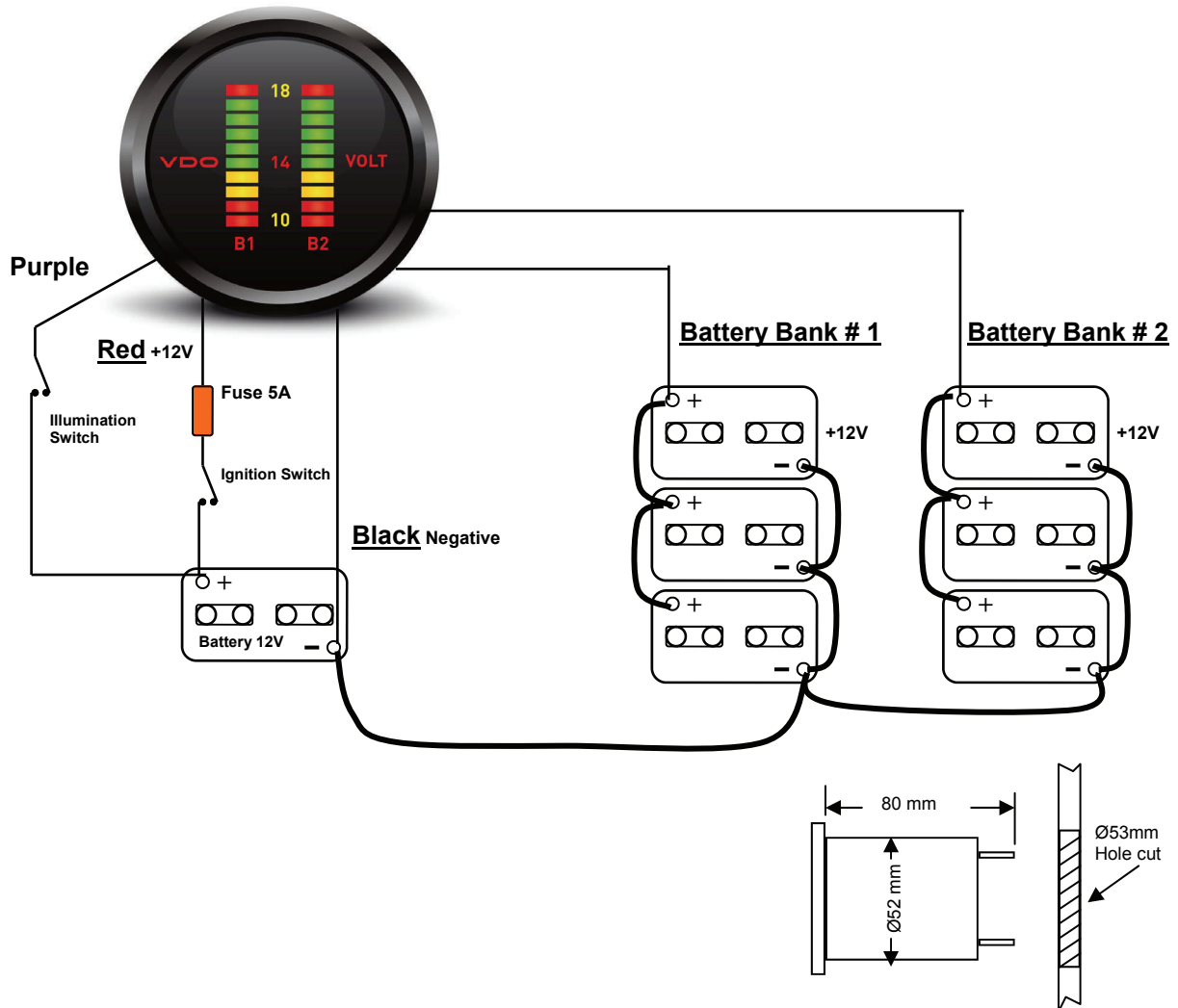

Installation

1. Cut a $\varnothing 53\text{mm}$ diameter hole and fit gauge.
2. Connect the **black** wire to a good chassis ground.
Ensure good ground connection between temperature sender unit.
3. Connect the **red** wire to a fuse accessory or the ignition switch circuit.
4. Connect the gauge **Orange** wire to the Battery terminal via an Ignition controlled
5. Display Dimmer connect the **purple** wire to headlights or parkers 12V to cut the brightness by 50% .

Note: If the **purple** wire is not connected to the headlights, then it should be earthed (battery neg).

Digital Air/Fuel Ratio Gauge

P/n 301.440

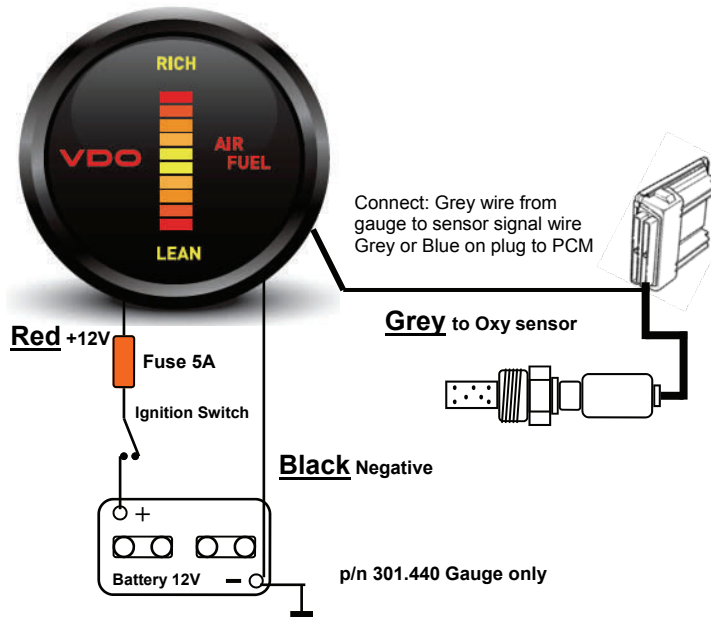

Oxygen Sensor Wide Band 0 - 5V

There are four different type of oxygen sensors with 1, 2, 3 or 4 wires connector.

The 3 and 4 wire sensors have inbuilt a heating element.

The VDO Oxygen sensor has Grey (or Blue) signal wire on a four terminals connector.

Connect the digital gauge p/n 301.440 Air/Fuel Ratio, Grey wire to the oxygen sensor Grey (or Blue) wire.

The gauge can be used for Unleaded Petrol, Methanol, Ethanol and Propane.

Note: Gauge is designed to operate off a "Wide band" Oxy Sensor 0 - 5V

Installation

1. Cut a Ø53mm diameter hole and fit gauge.
2. Disconnect battery
3. Connect the **black** wire to a good chassis ground.
Ensure good ground connection between oxygen sender unit.
4. Connect the **red** wire to a fuse accessory or the ignition switch circuit.
5. Connect the gauge's **grey** wire to grey or blue Oxygen sensor plug to PCM (Powertrain Control Module).
6. Re-connect the battery

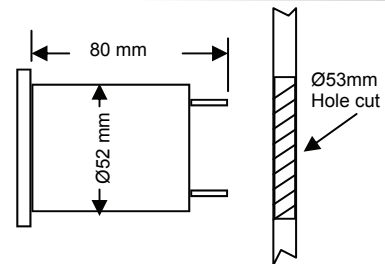

Air Fuel Ratio Instructions

The air fuel ratio gauge consists of 10 LEDs (light emitting diode) to represent the air to fuel ratio.

When power is applied to the gauge, the word rich will light at the top, of the gauge and the word lean will light at the bottom of the gauge.

The gauge works by monitoring the 0 to 5 Volt signal coming from the oxygen sensor.

The higher the voltage, the richer the condition. The lower the voltage, the leaner the condition.

When the vehicle is running full rich all the LED light bars will be lit.

The lit bars start at the bottom and will progressively light to the top. Each bar represents 0.5 Volt.

2 red, 2 yellow and 1 green represents a stoichiometric condition, (lowest emissions).

0 to 1.5 Volt, (or less), 2 red, 1 yellow represents a lean condition.

This is fine at idle or low cruising speeds.

At full throttle, heavy load condition, the gauge should have most or all of the bars lit. If the vehicle is computer equipped then the gauge will fluctuate up and down, at cruising or idle speeds, this is normal. The computer is constantly adjusting the air/fuel ratio for lowest emissions. The stoichiometric air/fuel ratio is the chemically correct ratio at which all of the oxygen and all of the fuels consumed. This condition is neither rich nor lean. This condition represents lowest emission, however maximum horsepower is developed at a rich condition.

A lean condition under load, is dangerous and could result in severe engine damage.

A faulty oxygen sensor or bad ground could cause the gauge to indicate a lean condition.

All sensors are supposed to operate the same however our tests have shown that some sensors are sluggish compared to others.

A heated sensor is not needed unless you need to get an instantaneous reading when the car is first turned on. It is recommended that you bring the engine up to normal operating temperatures before racing the engine.

By this time the sensor will also be up to operating temperature.

Fouling or permanent damage will occur if using the sensor with leaded or fuel additives containing lead, 2 cycle gasoline (gas + oil mixture), diesel fuel, nitro methane, or excessively rich mixture.

Digital Pyrometer Gauge

P/n 310.520

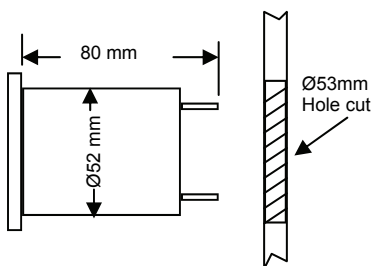
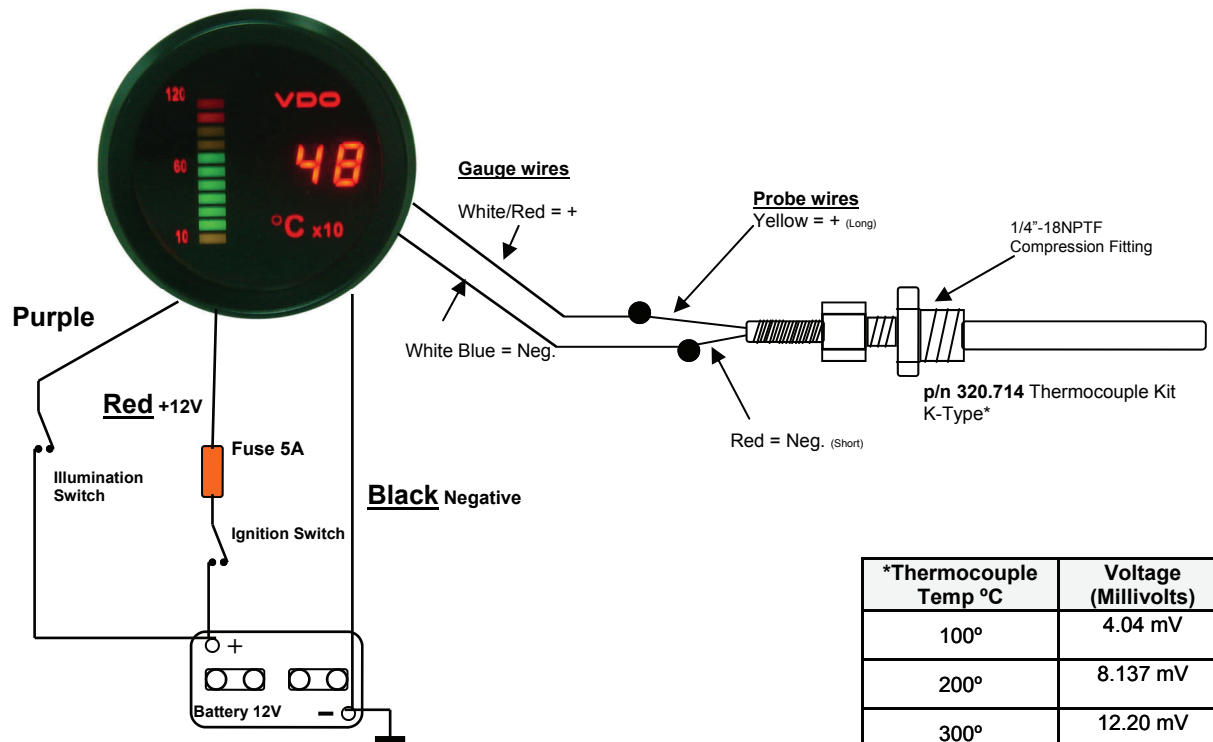

Pyrometer Kit p/n 310.521
 Includes:
 310.520 Gauge
 320.714 Thermocouple
 320.059 Weld Boss
 240.035 Loom 5mts

Gauge	White/Blue	White /Red
Loom	Red (-)	Brown (+)
Thermocouple	Red (-)	Yellow (+)

*Thermocouple Temp °C	Voltage (Millivolts)
100°	4.04 mV
200°	8.137 mV
300°	12.20 mV
400°	16.4 mV
500°	20.64 mV
600°	24.90 mV
700°	29.12 mV
800°	33.27 mV
900°	37.32 mV

Installation

1. Cut a Ø53mm diameter hole and fit gauge.
2. Connect the **black** wire to a good chassis ground.
Ensure good ground connection between temperature sender unit.
3. Connect the **red** wire to a fuse accessory or the ignition switch circuit.
4. Connect the gauge **Orange** wire to the Battery terminal via an Ignition controlled
5. Display Dimmer connect the **purple** wire to headlights or parkers 12V to cut the brightness by 50% .

Note: If the **purple** wire is not connected to the headlights, then it should be earthed (battery neg).

Digital Turbo Gauge

P/n 350.410

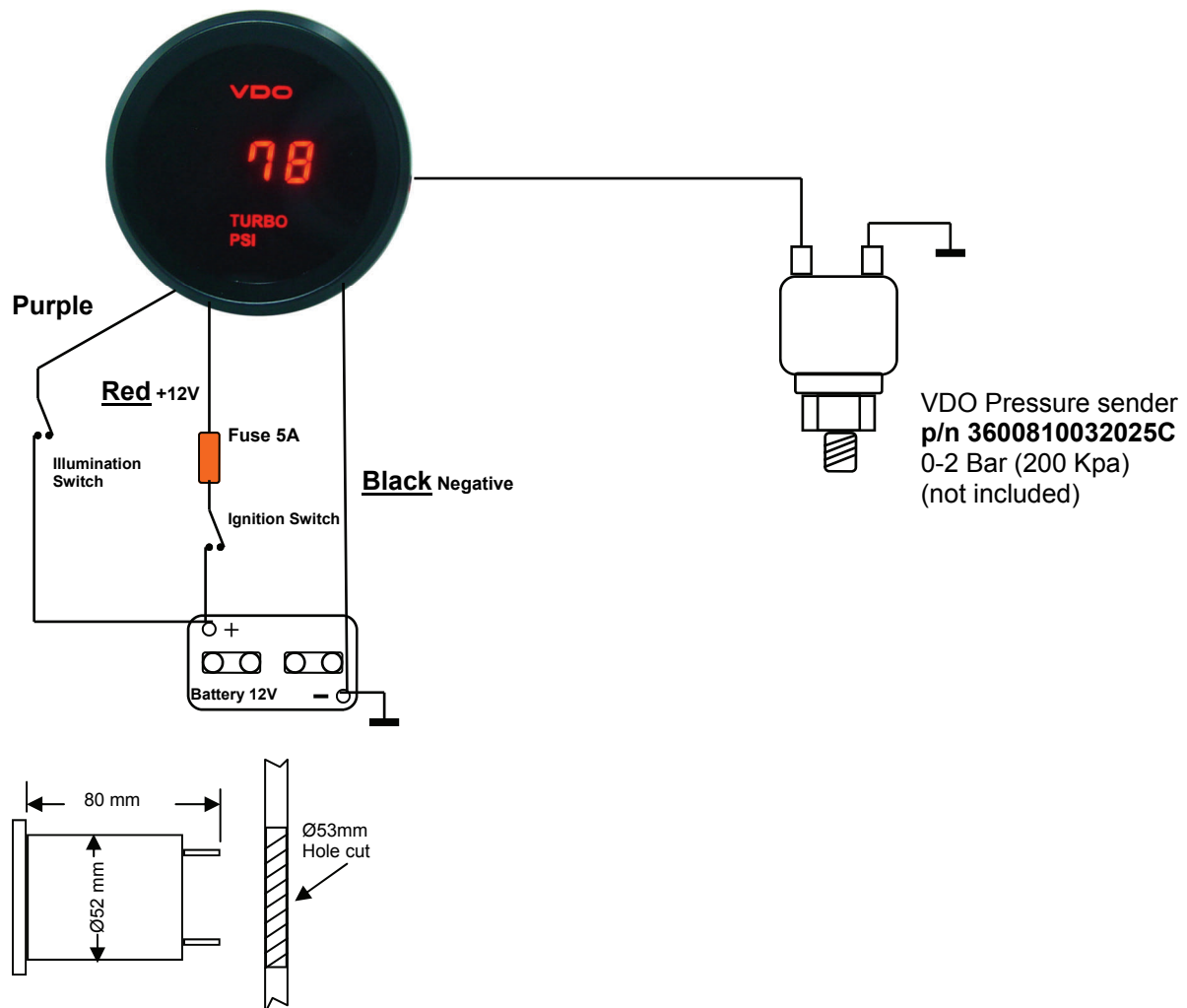

Installation

1. Cut a Ø53mm diameter hole and fit gauge.
2. Connect the **black** wire to a good chassis ground.
Ensure good ground connection between temperature sender unit.
3. Connect the **red** wire to a fuse accessory or the ignition switch circuit.
4. Connect the gauge **Orange** wire to the Battery terminal via an Ignition controlled
5. Display Dimmer connect the **purple** wire to headlights or parkers 12V to cut the brightness by 50% .

Note: If the **purple** wire is not connected to the headlights, then it should be earthed (battery neg).



General Notes:

Mark and cut hole on instrument panel, hole size should be 1mm greater than gauge body diameter, eg: (52mm diameter gauge cut a 53mm diameter hole)

Ensure clearance for the gauge depth, eg: 50mm or 80mm, depending on type of gauge installed.

Before beginning installation, disconnect the negative terminal on the battery, otherwise you risk a short circuit. If the vehicle is supplied by auxiliary batteries, you must also disconnect the negative terminals on these batteries!

Insulate exposed stranded wires to prevent short circuits.

When working on the on-board electronics, do not wear metallic or conductive jewelry such as necklaces, bracelets, rings, etc.

When installation is completed, re-connect the ground cable tightly to the negative terminal of the battery.

Check gauge for correct function.

Warranty Policy

VDO warrants all merchandise against defects in factory workmanship and materials for a period of 24 months after purchase.

This warranty applies to the first retail purchaser and covers only those products exposed to normal use or service.

Provisions of this warranty shall not apply to a VDO product used for a purpose for which it is not designed, or which has been altered in any way that would be detrimental to the performance or life of the product, or misapplication, misuse, negligence or accident.

On any part or product found to be defective after examination by VDO will only repair or replace the merchandise through the original point of purchase or on a direct basis.

VDO assumes no responsibility for diagnosis, removal and/or installation labour, loss of vehicle use, loss of time, inconvenience or any other expenses.

The warranties herein are in lieu of any other expressed or implied warranties, including any implied warranty of merchantability or fitness, and any other obligation on the part of VDO, or selling dealer.

The illustrations, information and specifications presented and referred to in this installation instructions are believed to be correct at the time of publication; however, accuracy cannot be absolutely guaranteed. VDO reserves the right to make changes from time to time without notice or obligation, in the specifications, design, colour or materials, and to change or discontinue models.

Continental Pty Ltd
2 Scholar Drive, Bundoora Vic 3083
VDO - A Trademark of the Continental Corporation

www.vdo.net.au
Ph +61(3) 94681151 Fax +61 (3) 94681502